



K. K. Wagh Institute of Engineering Education & Research, Nashik
(An Autonomous Institute From A.Y. 2022-23)

WINTER-2025	
Exam Seat No.:	
Academic Year:2025-2026	Semester:I
Class:FY	Program:B.Tech
Branch Code:FYE	Pattern:2022
Name of Course:Applied Mathematics - I	Course Code:FYE221001
Max. Marks:60	Duration:2.30 Hrs.

Instructions: Candidates should read carefully the instructions printed on the Question Paper and on the cover page of the Answer Book, which is provided for their use.

1. This question paper contains 3 page(s).
2. Answer to each new question is to be started on a new page.
3. Assume suitable data wherever required, but justify it.
4. Draw the neat labelled diagrams, wherever necessary.
5. Use of non-programmable pocket calculator is allowed.
6. The last columns indicates the Course Outcome and level of Blooms Taxonomy of the Question/sub-question.

Marks CO

Question No. 1

- 1 Solve the Traffic Problem. (6) CO3

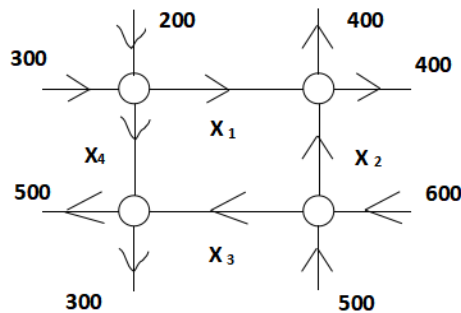

Question No. 2

- 2 Reduce the matrix A to diagonal form, also write Modal Matrix and Spectral matrix (6) CO3

$$A = \begin{bmatrix} 5 & 0 & 1 \\ 0 & -2 & 0 \\ 1 & 0 & 5 \end{bmatrix}$$

Question No. 3

- 3.a) If $u = e^{(x^2 + y^2)}$ then find (4) CO2
- i) u_x ii) u_y iii) u_{xy} iv) u_{yx} .

OR

3.b) If $u = y \log(1 + x^2)$ then find $\frac{\partial u}{\partial x}, \frac{\partial u}{\partial y}, \frac{\partial^2 u}{\partial x^2}, \frac{\partial^2 u}{\partial y^2}$ (4) CO2

3.c) If $u = \frac{1}{x^2} + \frac{\log x - \log y}{x^2 + y^2}$ then Prove that $xu_x + yu_y + 2u = 0$ (6) CO3

OR

3.d) If $u = \log\left(\frac{x^3 + y^3}{3x + 4y}\right)$ then prove that $x^2 \frac{\partial^2 u}{\partial x^2} + 2xy \frac{\partial^2 u}{\partial x \partial y} + y^2 \frac{\partial^2 u}{\partial y^2} = 2$ (6) CO3

3.e) If $u = f(rs), r = x^2 + y^2, s = x^2 - y^2$ then prove that $y \frac{\partial u}{\partial x} + x \frac{\partial u}{\partial y} = 4xy \frac{\partial u}{\partial r}$ (6) CO3

OR

3.f) If $u = F[x-y, y-z, z-x]$ then prove that $u_x + u_y + u_z = 0$ (6) CO3

Question No. 4

4.a) For a projectile motion, if the initial velocity u has an error of 2 % & angle θ has 1% error. Find % error in computing the horizontal range given by $R = \frac{u^2 \sin 2\theta}{g}$. The correct angle is 45° (5) CO5

OR

4.b) A dataset feature in a software computes the volume of a hydraulic cylinder. If there are 3 % & 1 % errors in measuring height & base radius, respectively. Find the % error in the calculated volume by a dataset feature. (5) CO5

4.c) If $ux = yz, vy = zx, wz = xy$, find $\frac{\partial(u, v, w)}{\partial(x, y, z)}$ (5) CO3

OR

4.d) If $x = u + e^{-v} \sin u, y = v + e^{-v} \cos u$, Find $\frac{\partial u}{\partial y}$ (5) CO3

4.e) A load distribution on a beam cross-section is modelled by $L(x, y) = 3x^2 - y^2 + x^3$ Find the values of x & y that produce maximum load capacity. Also find its maximum value. (6) CO5

OR

4.f) Find the largest product of the numbers x, y, z where $x^2 + y^2 + z^2 = 9$ (6) CO5

Question No. 5

5.a) A box contains 15 batteries, out of which 10 are good and 5 are defective. The device requires 3 batteries (5) CO3

If 3 batteries are selected at random.

1) find the probability that the device works (all 3 batteries are good)

2) Find the probability that exactly 2 of the selected batteries are good.

OR

5.b) When two dice are thrown find the probability that (5) CO3

1. The number 4 is in the first die
2. The sum of the numbers on the faces is 8
3. The sum of the numbers on the faces is 15

5.c) A team of 8 researchers is to be formed from 12 computer Engineers and 9 Electronics engineers. The team must include at least 4 computer engineers and at least 2 Electronics engineers (5) CO2

1) How many different teams can be formed under these conditions

2) How many of these teams will have exactly 5 computer engineers

3) How many of these teams will have exactly 2 Electronics Engineers

OR

5.d) If $P(A) = 0.1$, $P(B') = 0.35$, $P(A \cup B) = 0.7$ then Find (5) CO2
i) $P(A')$ ii) $P(B)$ iii) $P(A \cap B)$ iv) $P(A' \cup B')$ v) $P(A/B)$.

5.e) In a population of workers, suppose 40% are school graduates, 50% are high school graduates, and 10% are college graduates. The unemployed graduates among the school graduates, high school graduates and college graduates are 10%, 5%, and 2% graduates respectively are unemployed. What is the probability that he is a college graduate. (6) CO3

OR

5.f) A bag I contains 3 red and 4 black balls, while another bag II contains 5 red and 6 black balls. One ball is drawn at random from one of the bags, and it is found to be red. Find the probability that it was drawn from bag II. (6) CO3

..... End of question paper.....