



**K. K. Wagh Institute of Engineering Education & Research, Nashik**  
(An Autonomous Institute From A.Y. 2022-23)

WINTER-2025	
Exam Seat No.:	
Academic Year:2025-2026	Semester:VI
Class:TY	Program:B.Tech
Branch Code:MEC	Pattern:2022
Name of Course:Machine Design-II	Course Code:MEC223011
Max. Marks:60	Duration:2.30 Hrs.

**Instructions:** Candidates should read carefully the instructions printed on the Question Paper and on the cover page of the Answer Book, which is provided for their use.

1. This question paper contains 03 page(s).
2. Answer to each new question is to be started on a new page.
3. Assume suitable data wherever required, but justify it.
4. Draw the neat labelled diagrams, wherever necessary.
5. The last columns indicates the Course Outcome and level of Blooms Taxonomy of the Question/sub-question.

**Marks CO**

**Question No. 1**

- 1a) The following data is given for a pair of spur gears with  $20^\circ$  full-depth involute teeth: (6) CO1

number of teeth on pinion = 24,  $Y_p$  is 0.337

number of teeth on gear = 56,  $Y_g=0.417$

speed of pinion = 1200 rpm, module = 3 mm, service factor = 1.5

face width = 30 mm

Both gears are made of steel with an ultimate tensile strength of.  $600 \text{ N/mm}^2$ . Using the velocity factor to account for the dynamic load, calculate

(i) beam strength;

(ii) velocity factor; and

(iii) rated power that the gears can transmit

without bending failure, if the factor of safety is 1.5.

Given:  $C_v = 3/(3+V)$

**Question No. 2**

- 2a) A pair of straight bevel gears is made of grey cast iron FG 200 ( $E = 114\,000 \text{ N/mm}^2$ ). The surface (6) CO1  
endurance strength is  $90 \text{ N/mm}^2$ . The number of teeth on the pinion and gear are 30 and 40  
respectively. The module and the face width are 6 mm and 50 mm respectively. The pressure angle  
is  $20^\circ$ . Determine the wear strength of the tooth.

**Question No. 3**

- 3a) A transmission shaft rotating at 720 rpm and transmitting power from the pulley P to the spur gear G is shown in Fig. The belt tensions and the gear tooth forces are as follows:  $P_1 = 498 \text{ N}$   $P_2 = 166 \text{ N}$   $P_t = 497 \text{ N}$   $P_r = 181 \text{ N}$  The weight of the pulley is 100 N. The diameter of the shaft at bearings B1 and B2 is 10 mm and 20 mm respectively. The load factor is 2.5 and the expected life for 90% of the bearings is 8000 h. Determine dynamic load capacity at B1 and B2. (8) CO2

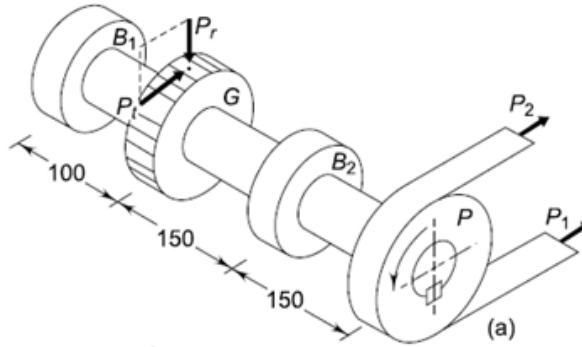

**OR**

- 3b) A taper roller bearing has a dynamic load capacity of 26 kN. The desired life for 90% of the bearings is 8000 h and the speed is 300 rpm. Calculate the equivalent radial load that the bearing can carry. (8) CO2
- 3c) A ball bearing, subjected to a radial load of 5 kN, is expected to have a life of 8000h at 1450 rpm with a reliability of 99%. Calculate the dynamic load capacity of the bearing, so that it can be selected from the manufacturer's catalogue based on a reliability of 90%. (8) CO2

**OR**

- 3d) A single-row deep groove ball bearing is subjected to a radial force of 9 kN and a thrust force of 4 kN. The values of X and Y factors are 0.56 and 1.5 respectively. The shaft rotates at 1500 rpm. The diameter of the shaft is 75 mm and Bearing No. 6315 ( $C = 112\,000 \text{ N}$ ) is selected for this application. (8) CO2

**Question No. 4**

- 4a) Derive the belt tension relationship for v belt drive with sketch (8) CO3

**OR**

- 4b) Write the steps for selection of flat belt from manufacture catalogue (8) CO3
- 4c) The layout of a leather belt drive transmitting 15 kW of power is shown in Fig. The centre distance between the pulleys is twice the diameter of the bigger pulley. The belt should operate at a velocity of 20 m/s approximately and the stresses in the belt should not exceed 2.25 N/mm<sup>2</sup>. The density of leather is 0.95 g/cc and the coefficient of friction is 0.35. The thickness of the belt is 5 mm. Calculate: (i) the diameter of pulleys; (ii) the length of belt; (8) CO3

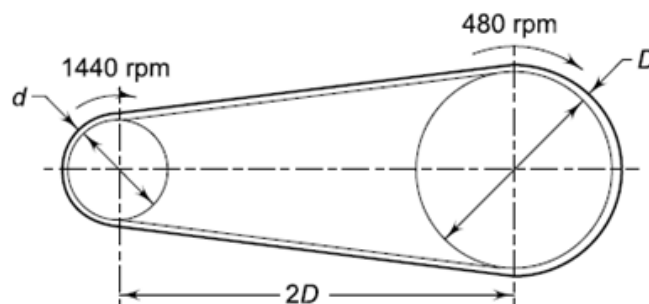

**OR**

- 4d) It is required to design a V-belt drive to connect a 7.5 kW, 1440 rpm induction motor to a fan, running at approximately 480 rpm, for a service of 24 h per day. Space is available for a centre distance of about 1 m. Diameter of smaller pulley is 200 mm. Determine the correct length of belt & wrap angle for small and bigger pulley. (8) CO3

**Question No. 5**

- 5a) Derive the equation for spring rate if spring are connected in series and if connected in parallel (8) CO4

**OR**

- 5b) Write the steps for design a helical spring. (8) CO4

- 5c) A helical compression spring, made of circular wire, is subjected to an axial force, which varies from 2.5 kN to 3.5 kN. Over this range of force, the deflection of the spring should be approximately 5 mm. The spring index can be taken as 5. The spring has square and ground ends. The spring is made of patented and cold-drawn steel wire with ultimate tensile strength of 1050 N/mm<sup>2</sup> and modulus of rigidity of 81370 N/mm<sup>2</sup>. The permissible shear stress for the spring wire should be taken as 50% of the ultimate tensile strength. (8) CO4

Design the spring and calculate

- (i) wire diameter;
- (ii) mean coil diameter;
- (iii) number of active coils;
- (iv) Total number of coils

**OR**

- 5d) A helical tension spring is used in the spring balance to measure the weights. One end of the spring is attached to the rigid support while the other end, which is free, carries the weights to be measured. The maximum weight attached to the spring balance is 1500 N and the length of the scale should be approximately 100 mm. The spring index can be taken as 6. The spring is made of oil-hardened and tempered steel wire with ultimate tensile strength of 1360 N/mm<sup>2</sup> and modulus of rigidity of 81370 N/mm<sup>2</sup>. The permissible shear stress in the spring wire should be taken as 50% of the ultimate tensile strength. Design the spring and calculate (8) CO4

- (i) wire diameter;
- (ii) mean coil diameter;
- (iii) number of active coils;
- (iv) required spring rate; and
- (v) actual spring rate.

..... End of question paper.....