



K. K. Wagh Institute of Engineering Education & Research, Nashik
(An Autonomous Institute From A.Y. 2022-23)

| WINTER-2025 | |
|---------------------------------|---------------------|
| Exam Seat No.: | |
| Academic Year:2025-2026 | Semester:V |
| Class:TY | Program:B.Tech |
| Branch Code:MEC | Pattern:2023 |
| Name of Course:Machine Desgin-I | Course Code:2305301 |
| Max. Marks:60 | Duration:2.30 Hrs. |

Instructions: Candidates should read carefully the instructions printed on the Question Paper and on the cover page of the Answer Book, which is provided for their use.

1. This question paper contains 04 page(s).
2. Answer to each new question is to be started on a new page.
3. Assume suitable data wherever required, but justify it.
4. Draw the neat labelled diagrams, wherever necessary.
5. The last columns indicates the Course Outcome and level of Blooms Taxonomy of the Question/sub-question.

Marks CO

Question No. 1

- 1a) Two identical steel plates frame as shown in Fig. is used in circus for standing an elephant on frame (6) 01
at one end. The total weight of elephant through one leg is P acting on the frame is 20 kN. The plates are made of steel 45C8 with tensile yield strength of 380 N/mm^2 . The factor of safety is 2.5. Determine the plate thickness.

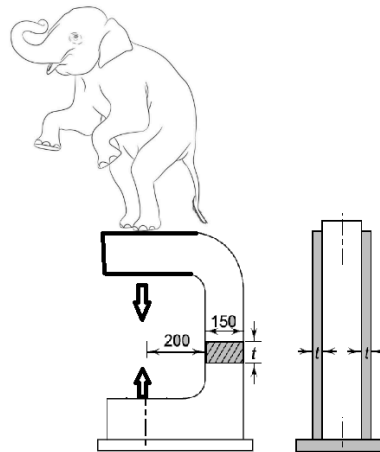

Question No. 2

- 2a) An intermediate shaft of a gearbox, supporting two spur gears A and B and mounted between two bearings C1 and C2, is shown in Fig. The pitch circle diameters of gears A and B are 500mm and 250 mm respectively. The shaft is made of alloy steel 20MnCr5. The factors k_b and k_t of the ASME code are 2 and 1.5 respectively. The gears are keyed hence maximum permissible stress is 83.7 N/mm^2 . Determine the shaft diameter using the ASME code. (6) 01

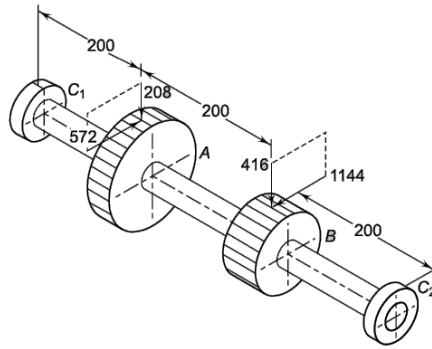

Question No. 3

- 3a) A machine vice, as shown in Fig., has single-start, square threads with 22 mm nominal diameter and 5 mm pitch. The outer and inner diameters of the friction collar are 55 mm and 45 mm respectively. The coefficients of friction for thread and collar are 0.15 and 0.17 respectively. The machinist can comfortably exert a force of 125 N on the handle at a mean radius of 150 mm. Assuming uniform wear for the collar, calculate
- (i) the clamping force developed between the jaws

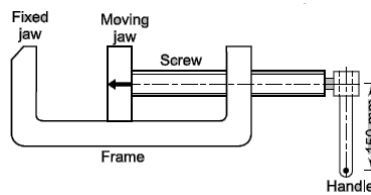

OR

- 3b) A power screw is used for opening and closing gate of water dam. The nominal diameter of a double threaded square screw is 50 mm, while the pitch is 8 mm. It is used with a collar having an outer diameter of 100 mm and inner diameter as 65 mm. The coefficient of friction at the thread surface as well as at the collar surface can be taken as 0.15. The screw is used to raise a load of 15 kN. Using the uniform wear theory for collar friction, calculate: torque required to raise the load. (8) 01, 02
- 3c) A triple-threaded power screw, with ISO metric trapezoidal threads is used to raise a load of 300 kN. The nominal diameter is 100 mm and the pitch is 12 mm. The coefficient of friction at the screw threads is 0.15. Neglecting collar friction, calculate
- (i) torque required to raise the load;
- (ii) torque required to lower the load

OR

- 3d) A triple-threaded power screw, with Acme threads is used to raise a load of 300 kN. The nominal diameter is 100 mm and the pitch is 12 mm. The coefficient of friction at the screw threads is 0.15. Neglecting collar friction, calculate
- (i) torque required to raise the load;
- (ii) torque required to lower the load

Question No. 4

- 4a) A forged rod is subjected to a reversed bending stress for 23736 cycle life. The bar is made of steel 40C8 ($S_{ut} = 600 \text{ N/mm}^2$). Calculate the bending stress of the bar if endurance limit is 100.64 N/mm^2 (8) 03

OR

- 4b) An automobile rotating shaft made of steel material is subjected to a completely reversed bending stress. Shaft material S_{ut} is 630 N/mm^2 the fatigue strength of the bar is 386.63 N/mm^2 . Calculate a life of rotating shaft in cycles. The corrected endurance limit of the bar is 315 N/mm^2 . (8) 03

- 4c) A rotating shaft in industrial application as shown in figure is subjected to a nonrotating Force of 10 kN. The shaft is machined from plain carbon steel having $S_{ut} = 500 \text{ N/mm}^2$. What is the life of the shaft, if fatigue strength of shaft is 242.54 N/mm^2 ? (8) 03

$K_a = 0.79, K_b = 0.85, K_c = 0.897$ and $K_d = 0.64$

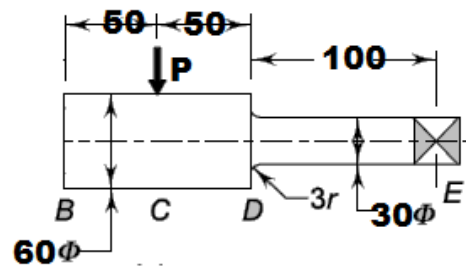

OR

- 4d) A cantilever beam made of cold drawn steel 20C8 ($S_{ut} = 540 \text{ N/mm}^2$) is subjected to a completely reversed load of 1000 N as shown in Fig. The notch sensitivity factor q at the fillet can be taken as 0.85 and the expected reliability is 90%. Determine fatigue strength of the beam for a life of 10000 cycles. Given: $K_a = 0.78, K_b = 0.85, K_c = 0.897$ and $K_d = 0.771$ (8) 03

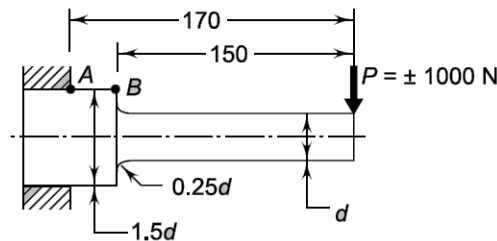

Question No. 5

- 5a) A steel plate subjected to a force of 10 kN and fixed to a channel by means of four identical bolts is shown in Fig. The bolts are made from plain carbon steel 45C8 ($S_{yt} = 380 \text{ N/mm}^2$) and the factor of safety is 2. Specify the diameter of bolt 1 (8) 01, 04

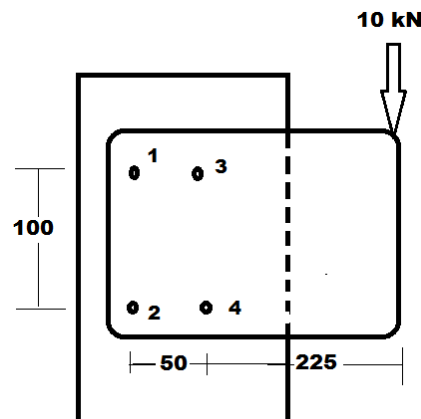

OR

- 5b) A cantilever load is present on bracket as shown in fig. for industrial application. Three identical bolts are used for fastened the bracket. The bolts are used of steel material having $S_{yt} 380 \text{ N/mm}^2$. Factor of safety 1.5. Determine diameter of bolt C. (8) 01, 04

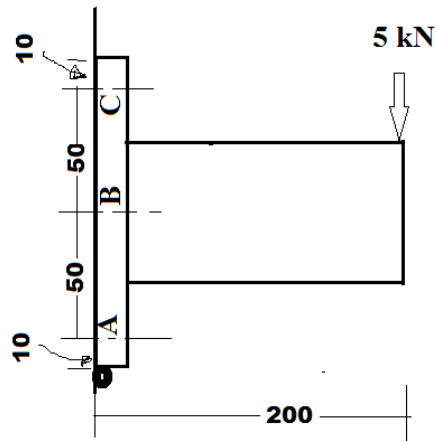

5c) How much length of a 10 mm fillet weld is required to weld the long side of an ISA angle 150 \ 75 \ 10 to a steel plate with side welds only? A static load of 125 kN acts through the centre of gravity of the angle section which is 53.2 mm from the short side. The allowable load per mm of the weld length is 665 N. (8) 01, 04

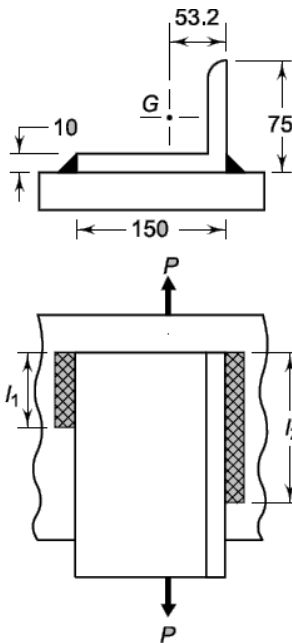

OR

5d) Two steel plates, 120 mm wide and 12.5 mm thick, are joined together by means of double transverse fillet welds as shown in Fig. The maximum tensile stress for the plates and the welding material should not exceed 110 N/mm². Find the required length of the weld, if the strength of weld is equal to the strength of the plates. (8) 01, 04

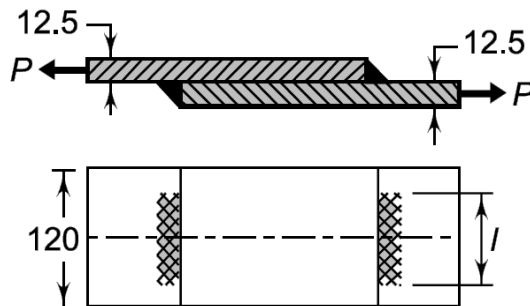

..... End of question paper.....